

Black Stump®

Pavers and Retaining Blocks

Gawler Stack Stone Pillar System™

Installation Guide

1. PREPARE THE FOUNDATION

Measure and mark out the location of the Pillar. Excavate the base hole approximately 500mm x 500mm wide and approximately 300mm deep for a fence pillar or 500mm deep if the pillar is for a pergola, garden arbor or verandah. Board up any sections of hole if necessary to screed a level top. Mix and pour the concrete into the hole, and while the concrete is green, push in some short lengths of reo bar at the centre of the concrete base as starter bars.

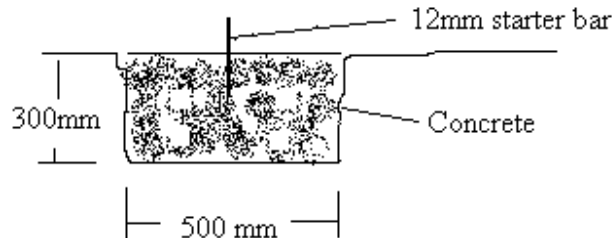

A typical fence pillar foundation

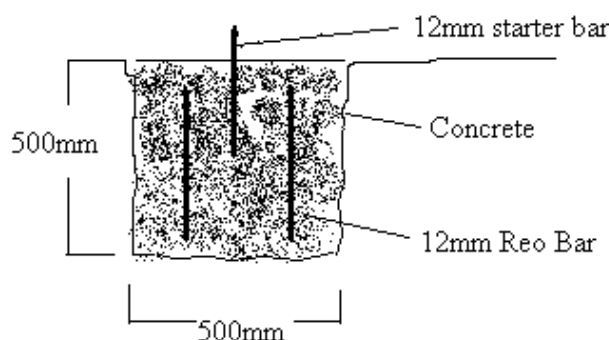

A typical pergola / arbor pillar foundation

2. BASE COURSE INSTALLATION

This is the most important course of the wall as the rest of the wall relies upon it. Accuracy is critical for a well constructed, good looking pillar. Spread a thin layer of mortar or tile adhesive across the foundation (thick enough to level off from the foundation variations). Place the first course of **Gawler Stack Stone Pillar™** block on the prepared base, tapping it down with a rubber mallet to ensure a good bedding.

Ensure the block is level, end to end, back to front. Use a string line for alignment of the other pillars.

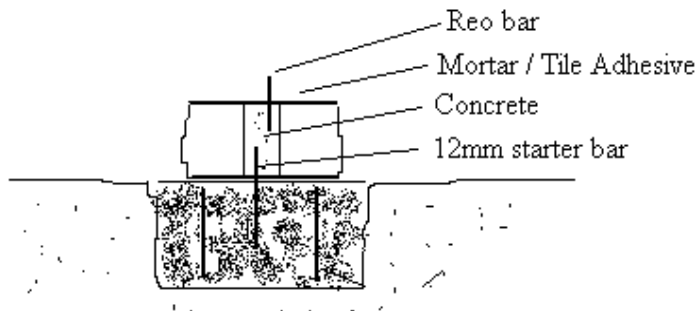

3. ADDITIONAL COURSES

Fill the block cavity from the previous course, with concrete. If desired spread a thin layer of mortar mix or tile adhesive on the top of the previous blocks, (note:- this is not essential though) . Place the next course of **Gawler Stack Stone Pillar™** block on top of the first, ensure the blocks butt together and for aesthetics, the stone joints should not run in line. Insert reo bars into the block cavity and push them down into the concrete filled cavity of the previous block, ensuring half of the rod length is inserted. Continue the process as you work up the pillar.

Note:- When using the **Mulga** fence rails with the **Stack Pillar**, after the first layer has been filled with concrete the succeeding layers may be glued together with Selleys Landscape Liquid Nails

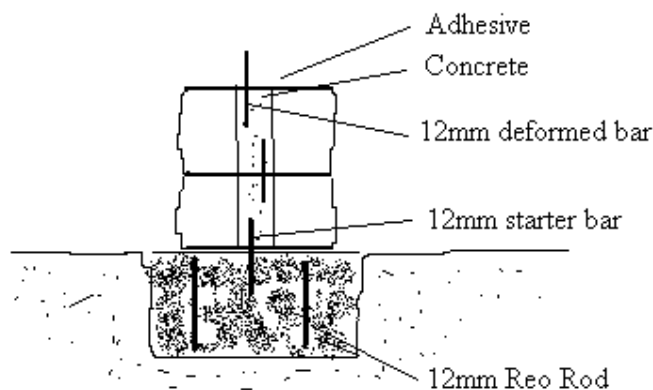

4. MIXING and MATCHING BLOCKS

To provide the best look and a more interesting random pattern, always rotate the blocks so the faces do not match up with the previous block.

The mail box blocks and inserts may be inserted into the pillar at any level and for magazines, install the Stack Pillar Mulga rail blocks.

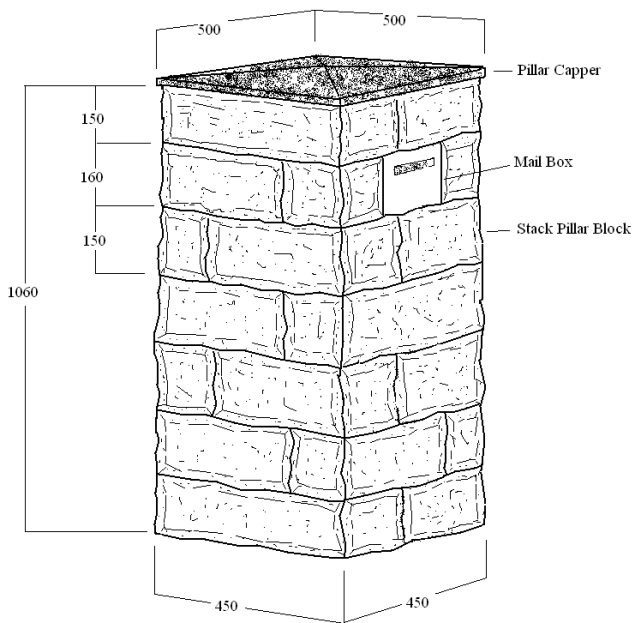

Stack Pillar Mail Box

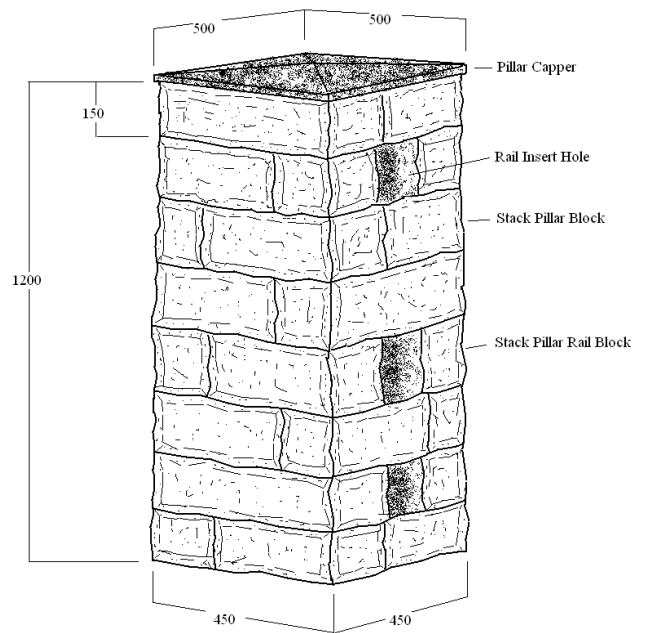

Stack Pillar for Mulga fence rails

5. CAPPING THE PILLAR

Clean off the top of the last course after filling the cavity. For the best results a mortar mix of 1 part cement to 4 parts sand will allow you to level the top capping and remove any slight level variations to the top block that may have occurred during the course of construction. Starting at the lowest point, tap the capping stone gently down into the mortar base, allowing overhang of the capping on both sides of the wall and ensuring the capping block is level end to end, front to back.

Hint:- For lighter coloured blocks use Brightonlite cement rather than grey Normal Portland. A colour oxide may be added to the mix if so desired.

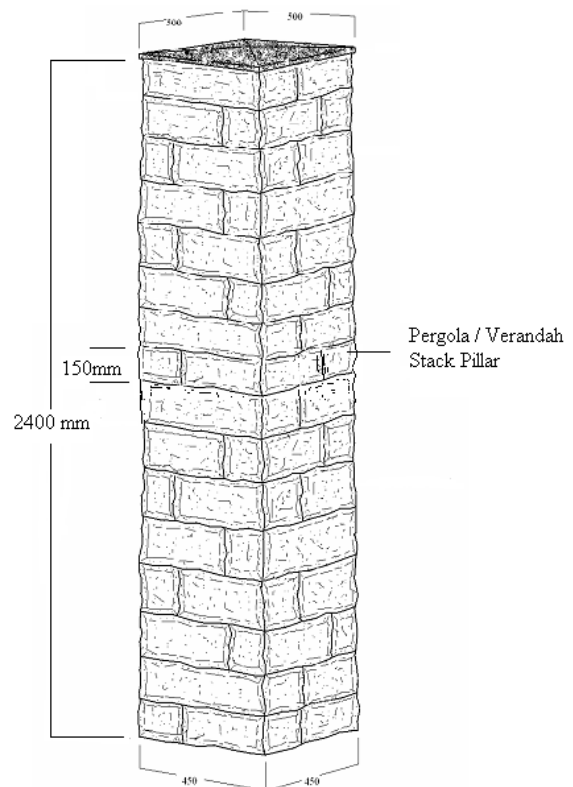

Pergola / Verandah Stack Pillar