

Black Stump®

Pavers and Retaining Blocks

Gammon™ and Kimberley™ Retaining Wall System

Installation Guide

1. PREPARE THE BASE

Measure and mark out the location of the wall. Remove all surface vegetation from the area. **Do not** use this as back fill. Excavate the base trench approximately 500mm wide and approximately 250mm deep for the length and layout of the wall. Start the excavation at the lowest level and step up in 150mm graduations as required. Level and compact 20mm rubble to 150mm depth.

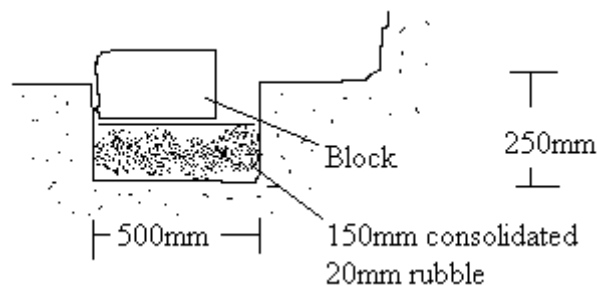

2. BASE COURSE INSTALLATION

This is the most important course of the wall as the rest of the wall relies upon it. Accuracy is critical for a well constructed good looking wall. Place the first course of **Gammon™** or **Kimberley™** 300 or 450 series blocks abutting one another on the prepared base. **Do not** use the 150 series blocks as part of the base course. Ensure each block is level, end to end, back to front. Use a string line for alignment of straight walls or PVC conduit bent around for curved walls.

3. DRAINAGE, BACKFILL & COMPACTION

Place slotted drain pipe behind the wall, ensuring adequate fall for the water to run away from the base of the wall. Cover with 20mm aggregate and fill block cavities as you proceed. Place backfill and compact in layers of no more than 150 mm.

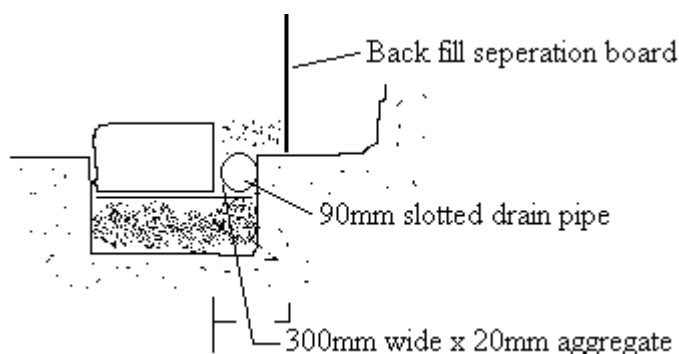

Hint:-
300mm out
vertical
side with

Place a sheet of ply or similar from the back of the wall. Hold between some stakes. Fill one the drainage aggregate and the

other with suitable back fill. As the wall height increases slide the separator board up to the new level. Keeps it neat, doesn't waste expensive aggregate.

3. ADDITIONAL COURSES

Place the next course of *Gammon*[™] or *Kimberley*[™] blocks on top of the first, ensure the blocks butt together and except for when using the 150V vertical blocks the joints should not run in line. Fill the block cavities with aggregate, back fill and compact the wall as you work up.

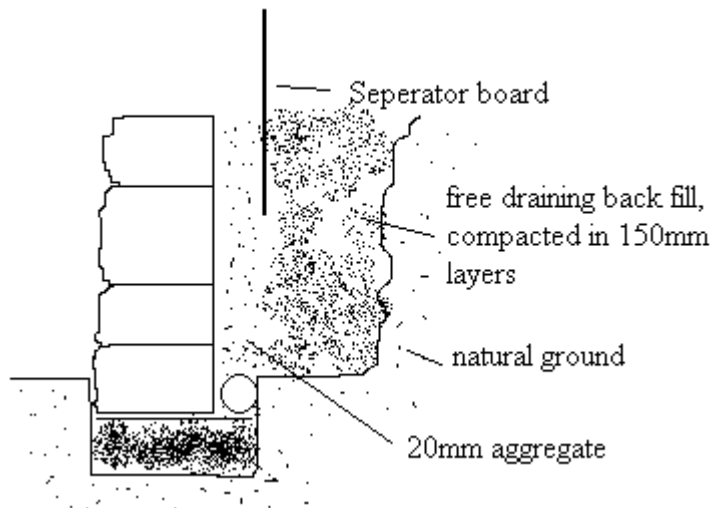

4. CORNERS & CURVES

To construct 90° corners use the *Gammon*[™] or *Kimberley*[™] 300EC block to end the course in one direction and start the next course on top overlapping the bottom block with the stone faces exposed either way. This will mean you will need a left and right hand end block.

For convex curves the *Gammon*[™] or *Kimberley*[™] 300 with the back corners cut off with a hammer and bolster creates a wedge shape, is the easiest way of constructing an external curve, mixed with standard *Gammon*[™] 150, 150V and 300 or *Kimberley*[™] series blocks to create the desired curve. On larger curves the *Gammon*[™] or *Kimberley*[™] 450 may also be suitable as well.

Concave curves are easily constructed with the *Gammon*[™] 150, 150V and 300 or *Kimberley*[™] series blocks and once again on larger curves the *Gammon*[™] 450 may also be used.

Note:- For tight curves the back edge of the blocks, to create more of a wedge shape, may need to be cut off with a hammer and bolster or an angle grinder or brick saw to decrease the radius even more.

Hint:- When constructing curves some sections of the bottom locating lug may be in the way, to create a nice even curve. Carefully mark the section of the locating lug that is not allowing the block to sit flat on the lower block and with a bolster and hammer remove that section, to allow the block to sit flat and square.

Do not remove the locating lug completely from the block, as this will not allow the block to lock into the wall and you will cause a weak point in the wall.

5. CAPPING THE WALL

Clean off the top of the last course after back filling the cavity. For the best results a mortar mix of 1 part cement to 4 parts sand will allow you to level the top capping and remove any slight level variations to the top blocks that may have occurred during the course of construction. Starting at the lowest point, tap the capping stone gently down into the mortar base, allowing 20 - 30mm overhang of the capping on the front of the wall and ensuring the capping block is level end to end, front to back.

Hint:- For lighter coloured blocks use Brightonlite cement rather than grey Normal Portland. A colour oxide may be added to the mix if so desired.

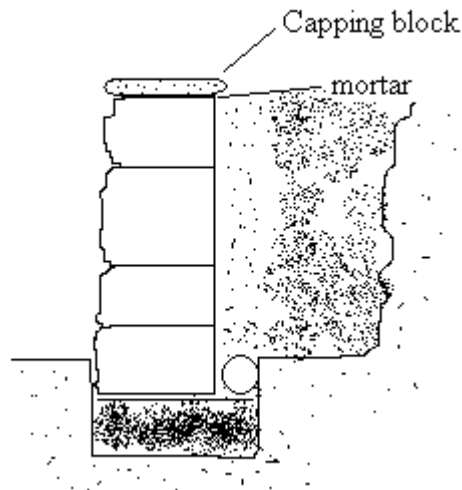

6. MIXING and MATCHING BLOCKS

Under most circumstances to provide the best look and at the same time a strong, robust wall the wall should be constructed mostly of **Gammon™** 300 and 450 series blocks with some 150 series blocks amongst them.

The **Gammon™** 150V and 300V are to provide a more interesting random pattern but should never be placed in the same course as one another. Always stagger these blocks throughout the wall construction. As a guide, one **Gammon™** 150V and 300V per every second course at least two linear metres apart.

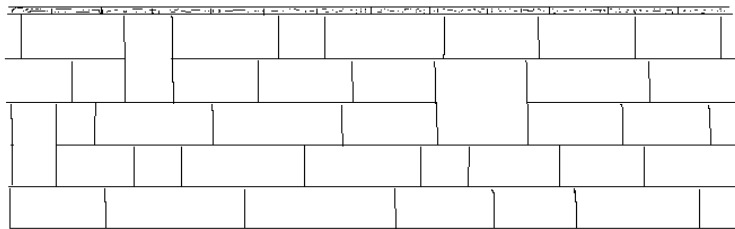

The beveled edged **Kimberley™** block range makes a very nice formal style wall by itself or for more interest may be used in conjunction with the **Gammon™** block to construct formal corner quoins. A very nice effect can be achieved by using the **Kimberley™** blocks for a base, corners and top layer and infill the rest of the wall with **Gammon™** blocks.

7. STEPS

Place the first row of **Gammon™** or **Kimberley™** step blocks on a 150mm consolidated rubble base, ensuring they are level and straight. Backfill behind the first row to the bottom of the rear recess in the step block with rubble, compact and level. Place the next row of step blocks interlocking the first row and then continue the process. The locating lug at the back of the last step will need to be cut off so that you can pave to the back of the step block.

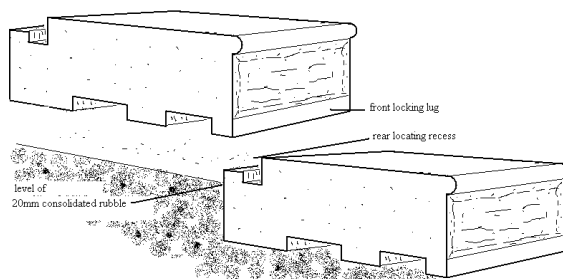

Guide to Wall Design

Note:- The following are only a guide to wall design. Any wall over one metre high requires an Engineers design and Local Council approval, before construction.

Vertical Gravity

Recommended only for walls with curves and 90° corners and to provide resistance

Note:- fill block drainage aggregate to together

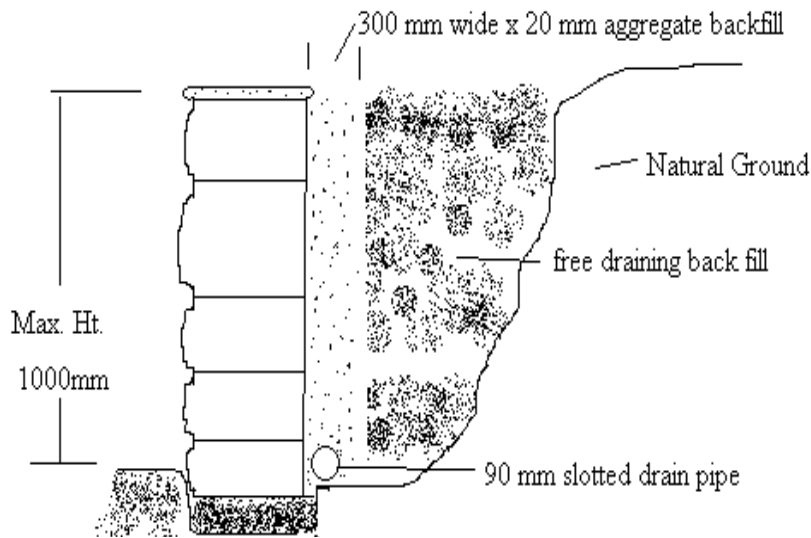

Wall

for walls with to add strength

cavities with help lock blocks

10 degree batter

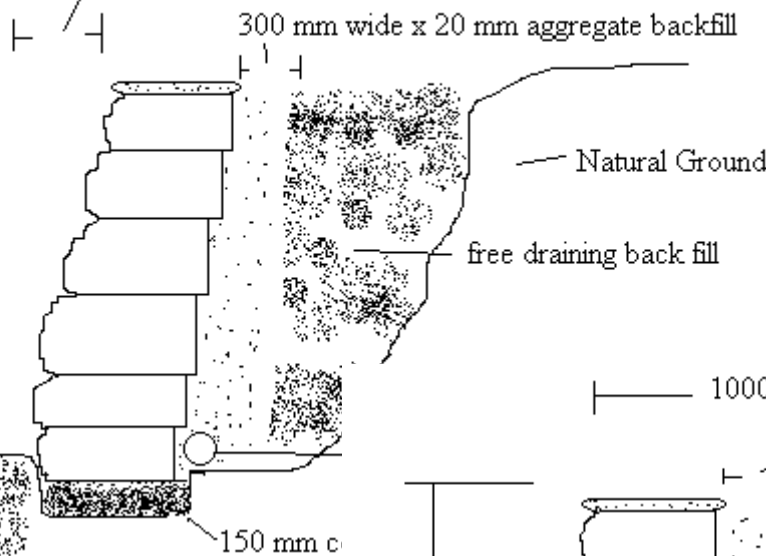

Battered Gravity Wall

Recommended for straight walls without curves, corners or geo textile reinforcing

Note:- fill block cavities with drainage aggregate to help lock blocks together

Max. Ht. 1000mm

1000mm Geo Textile
300mm width x 20 mm drainage aggregate

Reinforced Vertical Gravity Wall

Recommended for straight walls, walls with a surcharge or grade level above the wall height or any wall over one metre.

Note:- fill block cavities with drainage aggregate to help lock blocks together

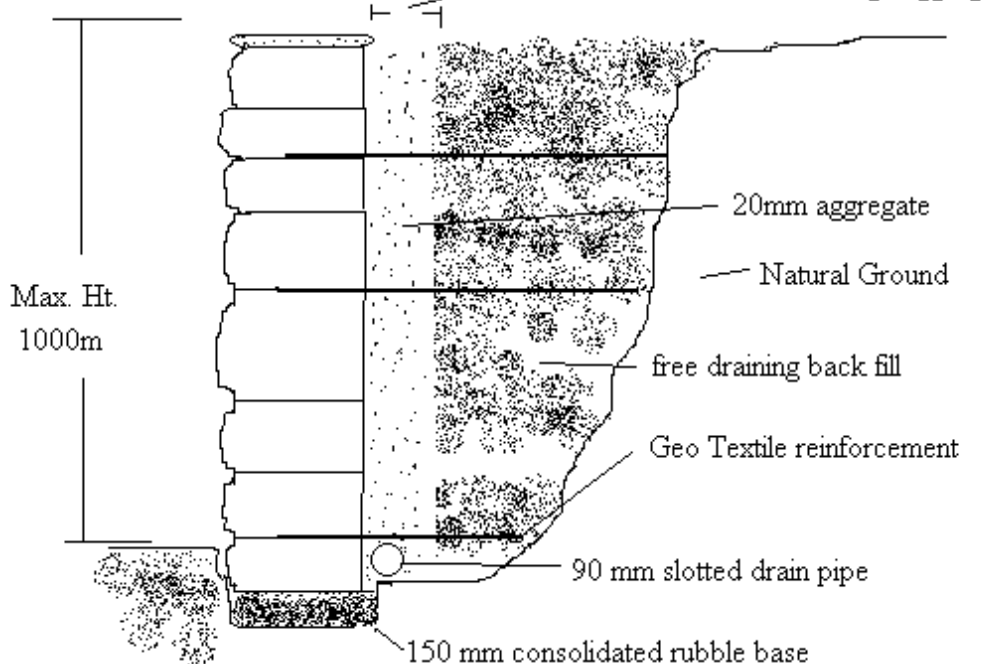

Max. Ht. 1000m

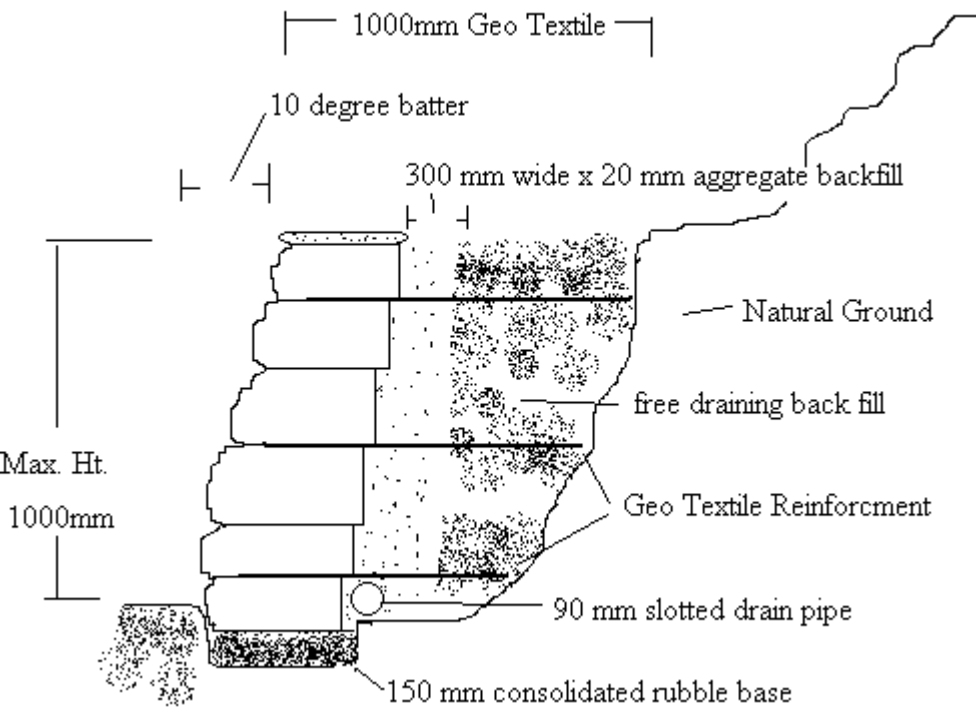

Reinforced Battered Gravity Wall

Recommended for straight walls, walls with a surcharge or grade level above the wall height or any wall over one metre.

Note:- fill block cavities with drainage aggregate to help lock blocks together

Reinforced Vertical Gravity Wall with Parapet

Note:- On retaining wall section, fill block cavities with drainage aggregate to help lock blocks together. The last 2 courses of the retaining wall blocks should be filled with concrete and reo bars and continue up for the parapet wall blocks.

